

**JENN-AIR**



**Use and Care Manual**

# **COMPACTOR**

**MODELS TC406 & TC406W**

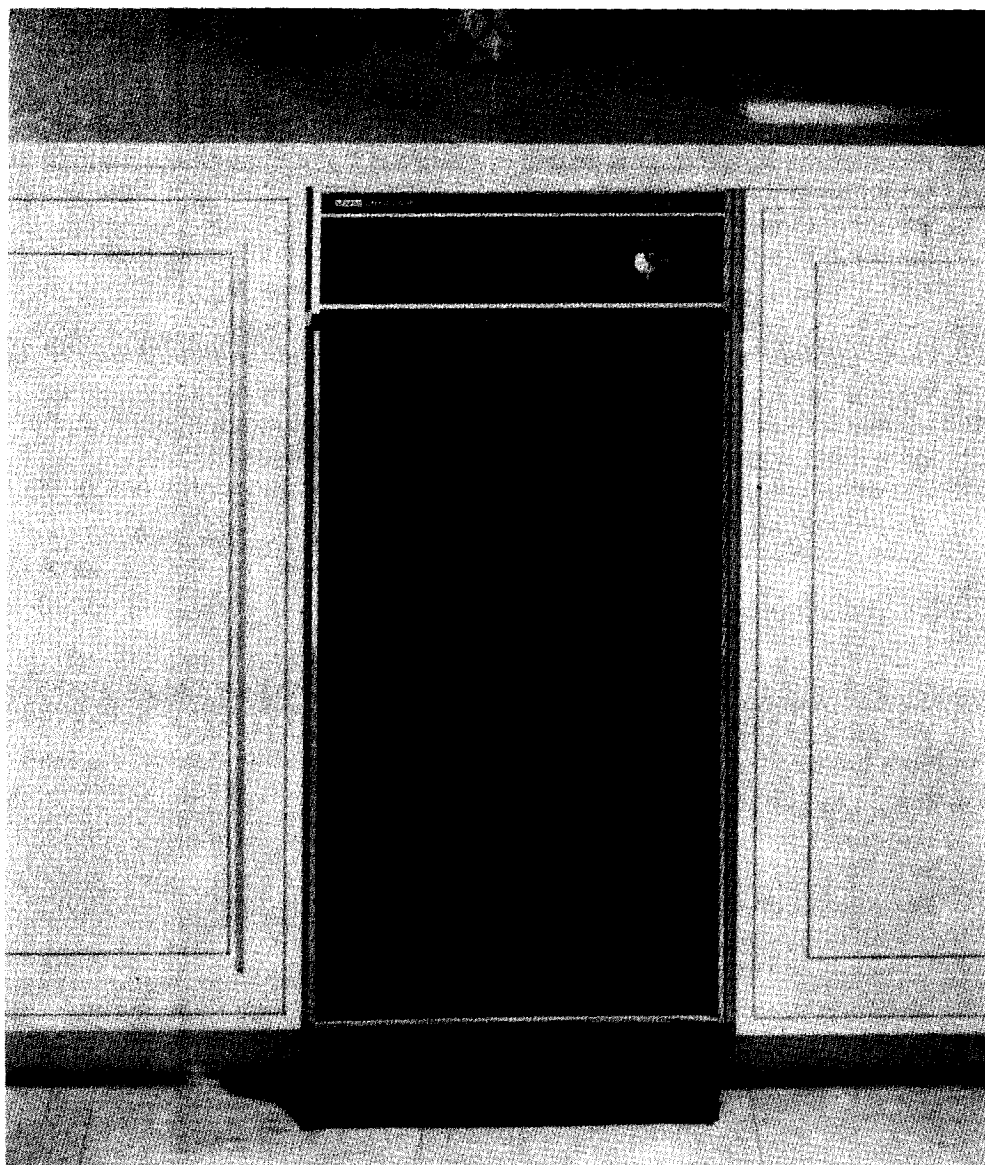

# SAFETY PRECAUTIONS

---

1. **Read** all instructions before using your compactor.
2. **Do not** let children operate or play with your compactor. Anything placed in the unit will be crushed or compacted.
3. **Keep** the compactor locked when it's not in use. Remove the key knob to a safe place.
4. **Use ample amounts of paper products in trash loads**, to decrease the chances of glass fragments piercing the bag.
5. **Always** place glass bottles, etc., on their sides in the center of the drawer so the wastepaper below and beside the bottle can help keep broken glass near the center of the bag, away from bag sides.
6. **Always** handle a filled compactor bag with care. Never lift it by the sides. Broken glass or other sharp objects in the bag can cause injury.
7. **Always** carry a filled compactor bag by the folded top or a bag carrier. Watch out for glass that may have cut through the bag sides.
8. **Do not** use the compactor for any purpose except the job it was designed to do.
9. **Before touching** the ram cover, wipe off any broken glass.
10. **Do not** shove items down into the compactor with hands or feet. To avoid being cut, let the compactor do the compacting.
11. **Do not** compact aerosol cans or any container or material which might contain poisonous or explosive products such as insecticides.
12. **Do not** compact cloths or cans containing paint liquids, thinners, lighter fluid, etc. which could create a fire hazard.
13. **Do not** spill any liquids on compactor top.

## INSTALLATION SAFETY

1. **OBSERVE ALL GOVERNING ELECTRICAL CODES AND ORDINANCES.**
2. **Be sure** your compactor is electrically grounded in an approved manner.
3. **Do not** remove the power supply cord ground prong.
4. **Do not** use an extension cord.
5. **Use care** when leveling your compactor, so that the unit does not drop on your hand.
6. **Use care** when changing front panels. As with any cut metal edges, they could cause injury if handled carelessly.
7. **Never** operate the compactor when the drawer handle is removed.
8. **Be sure** your compactor is properly installed in an appropriate level area and a place suitable for the size, function and protection of the compactor.

**SAVE THESE INSTRUCTIONS FOR FUTURE REFERENCE.**

---

# Parts of the Compactor

---

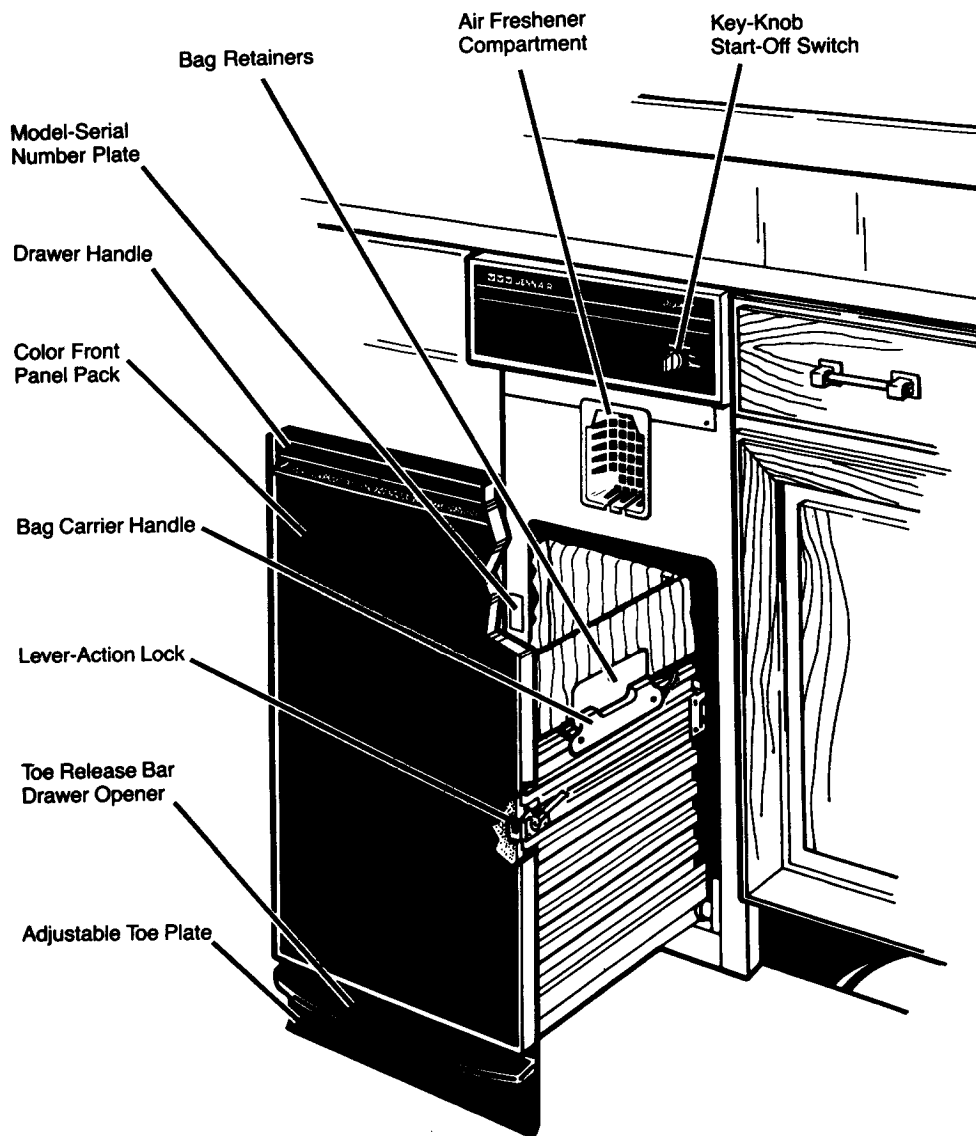

# Using the Compactor

---

## To Start

1. Open the drawer by pressing the toe release bar or pull handle.
2. Drop in the trash, folding or crushing oversized items. Make sure trash does not fall behind container. Never fill container beyond rim.
3. Close drawer completely or compactor will not operate.
4. Turn key-knob to START; let knob go. Compactor will automatically stop at the end of the cycle. When the compactor has stopped, the key-knob will remain at the ON position.

## To Stop

1. To stop compactor during a cycle, turn key-knob to LOCK/OFF. Then turn it to ON. The compacting ram will rise.
2. Once ram stops rising, drawer can be opened. Compactor is also ready for routine operation.

## To Lock

1. The compactor can be locked so that it cannot be operated. This is especially important to prevent small children from operating or playing with compactor.
2. To lock, turn key-knob to LOCK/OFF position, remove knob and place in a secure location. This locks the control panel but not the drawer. Therefore, before running the compactor, check to see if any item has been mistakenly placed in the drawer.

## Loading Tips

- The compactor is designed to handle most dry trash. However *it is not a substitute for a food waste disposer*. Most food waste will become sour and odoriferous when held at room temperature.
- Load bottles or cans on their sides in the *center* of the drawer.
- Wrap all wet or messy food waste in newspapers or paper towels to help absorb moisture.

## Do Not Compact The Following Items

- Highly flammable materials, such as paint or oil-filled rags and paint cans that might cause a concentration of explosive vapors and thus a fire hazard.
- Any container or aerosol can which might contain poisonous or explosive products.
- Items that may develop offensive odors such as raw meat, fish, citrus rinds, disposable diapers and personal hygiene items.

# Installing and Removing the Bag

## To Install New Bag

1. Before installing a new bag, be sure drawer side is securely locked and that the container is clear and free of sharp debris that could puncture the bag.
2. Fit the bag carrier in the drawer. Tuck the rope handles behind the bag retainers. (See Fig. A)
3. Put unopened bag in drawer as shown. Spread front bag corners and slide cuff over right-front corner. (See Fig. B).

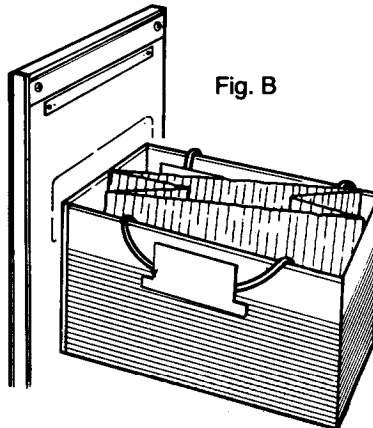
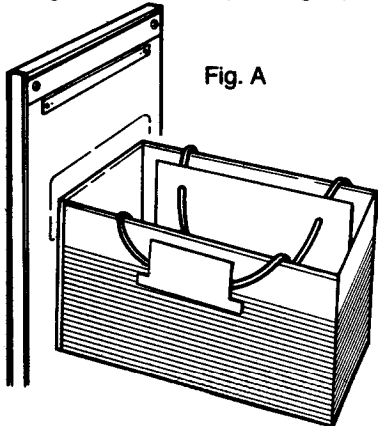

4. Spread rear corners and slide cuff over left-rear corner. Tuck cuffs behind bag retainers. (See Fig. C)
5. Press inside of bag against drawer bottom, sides and corners for smooth fit. (See Fig. D)

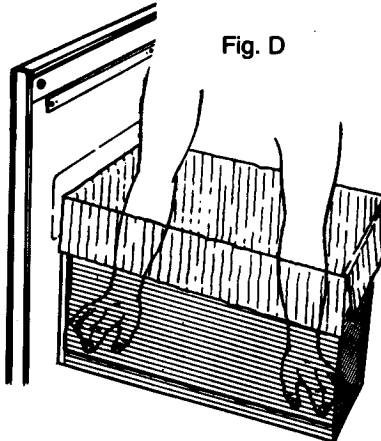
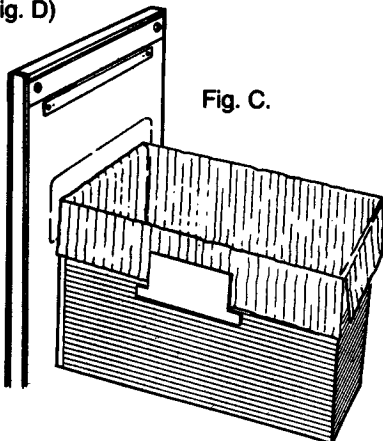

**NOTE:** A special type of disposable paper bag lined with plastic has been designed for use in the compactor. Additional bags may be purchased from any retail outlets that sell appliance parts and accessories and from Jenn-Air dealers (Jenn-Air Model TCB12). **DO NOT USE** paper grocery bags, plastic bags or bags other than the plastic-lined bags especially made for the compactor. These bags are neither strong enough or large enough to hold compacted waste.

## To Remove a Filled Bag

1. When the level of compacted trash nears the top of the bag and no more trash can be added, remove the bag.
2. Open drawer. Pull all four bag cuffs out of the retainers on the sides of the drawer; unfold flaps. Tuck in slotted sides. (See Fig. E)
3. Bring top edges of bag together. Roll or fold top edges to close bag. (See Fig. F)

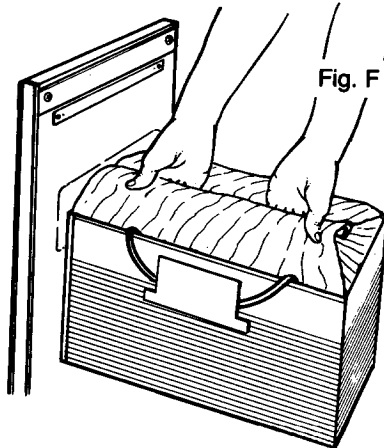
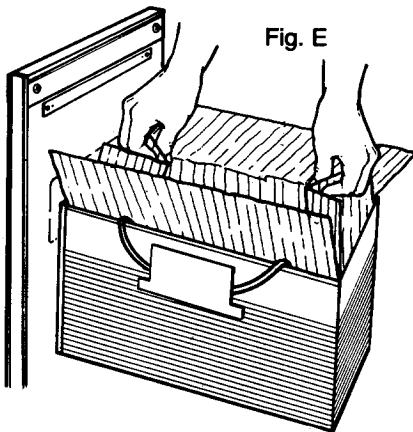

4. Remove bag carrier handles from side retainers and hold. (See Fig. G)
5. Press down lever-action lock located on right side of drawer (See Fig. H). Hold latch and tilt side of drawer until the latch clears the drawer front. Use bag carrier handles to lift out bag and carry away. If glass is in the bag, use care when handling bag. Do not pick bag up by sides.

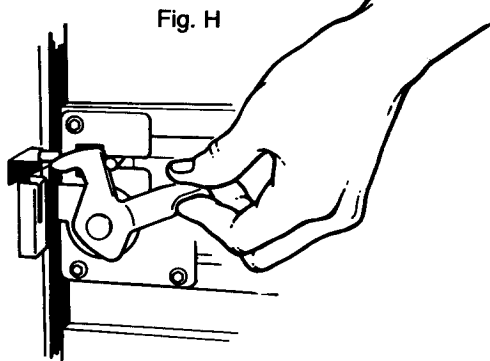
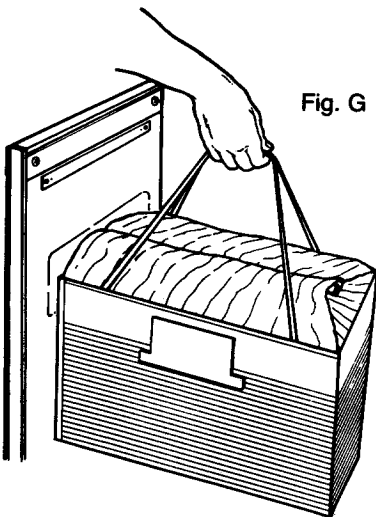

6. Push side of drawer to close. Lock the lever-action lock. Place clean bag in drawer.

# Other Hints on Caring for the Compactor

## Cleaning Compactor

**Exterior Surfaces:** Wipe with warm, sudsy water and a damp cloth. Rinse. Dry with a soft cloth.

**Inside of Drawer:** While cleaning inside of drawer, wear rubber gloves. There may be bits of glass in the drawer. Wash with a damp cloth using warm, sudsy water. Rinse and dry.

For ease in cleaning, the drawer side can be removed. Press down lever-action lock and tilt side of drawer; hold latch down until drawer clears. Lift out drawer side. (See Fig. I) To replace, slide it back in the tilted position. Press latch down and push side of drawer in upright position. Lock latch.

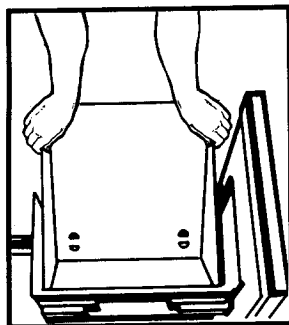

Fig. I

**Inside Cabinet:** Remove drawer by pulling it out until it stops. Note the tracks in which the drawer rollers move. Lift the front to clear the drawer stops. Grasp drawer on the sides, as shown in Fig. J, and lift out of cabinet. Set aside.

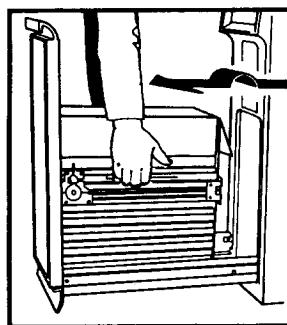

Fig. J

While drawer is out of cabinet, check the ram cover and clean if necessary. While wearing rubber gloves, wipe glass particles off ram cover with a cloth or paper towels. Use warm sudsy water to remove foods. Rinse and dry. (See Fig. K)

Vacuum inside of cabinet if necessary. While wearing rubber gloves, wash, rinse and dry cabinet interior.

To replace drawer, insert rollers into tracks. Lift drawer to clear stop tabs. Push in drawer.

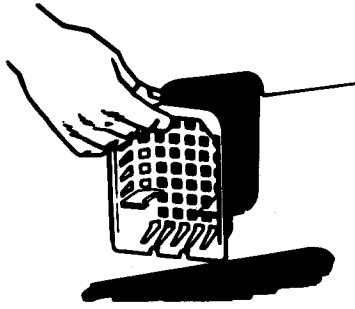

Fig. K

## **Air Freshener**

Using an air freshener will help control odors that might develop in the trash. Place a solid air freshener, such as a stick-on disc-shaped freshener, into the air freshener compartment. There are many solid air fresheners available at supermarkets and department stores. The air freshener should last 4 to 6 weeks depending on room temperature and how dry room air is.

Compartment that holds air freshener can be removed for cleaning if necessary.



## **Adjustable Toe Plate**

In some installations the toe plate may rub the floor covering. If this occurs, the toe plate clearance may be changed as follows:

- Determine the amount of interference of the toe plate with the carpet or flooring.
- Slide the drawer from the unit.
- Lay drawer bottom up.
- With a ruler and pencil draw a line where toe plate interferes with the floor covering.
- Use a pair of scissors and cut toe plate along this line.
- Replace drawer in the unit.



# Changing Front Panels

Your Jenn-Air Model TC406 compactor comes equipped with two reversible front panels painted Black/White and Almond/Harvest Gold. To change the color of your compactor's front panel, follow the directions below. All you need is a medium sized screwdriver.

(NOTE: Your Model TC406W compactor comes equipped with only one reversible front panel painted Black/White.)

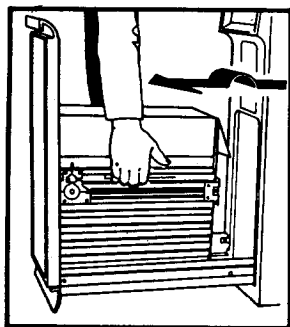
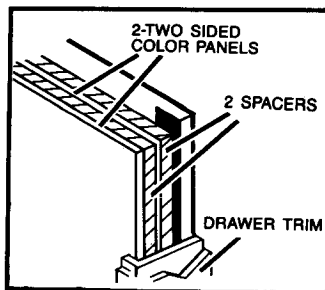

- Slide out drawer until it stops.
- Lift front to clear stops.
- Pull straight out.

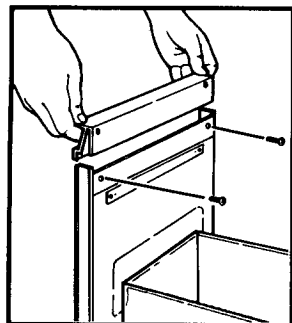

- Remove two screws shown.
- Remove handle.

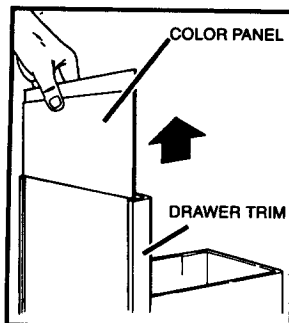

- Remove the color panel you want.
- Be careful – edges may be sharp.

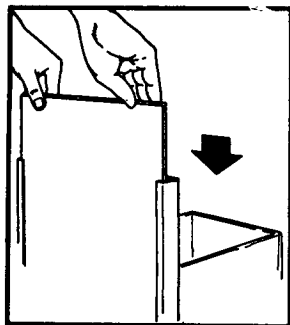

- Install desired color panel in front, behind drawer trim.
- Reinstall the remaining color panel between spacers.
- Make sure panels are all the way down.
- Replace handle and screws.

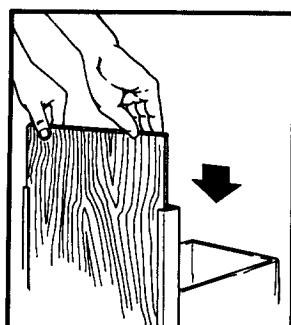

Option: Match your kitchen's color scheme by replacing color panels with your own creation (wallpaper, paneling). See "Installation Instructions."

- Replace the drawer:
  - Put drawer rollers over stops in the drawer guides.
  - Slide drawer back to stops.
  - Lift front of drawer to clear stops.
  - Slide it all the way in.

**• WARNING: REPLACE HANDLE BEFORE OPERATING COMPACTOR TO AVOID INJURY FROM MOVING PARTS.**

# Before You Call For Service

---

Check the following list to be sure a service call is really necessary. A quick reference of this manual, as well as reviewing additional information on items to check, may prevent an unneeded service call.

## If the compactor won't operate:

- Have you checked the main fuse or circuit breaker box?
- Is the drawer completely closed?
- Is the key-knob turned all the way to START before it is released?
- Is the electric cord securely plugged in?

## If compactor stops during operation:

- Push drawer in while turning key-knob to start. Repeat if necessary. Rearrange trash load – do not load rigid items at front of drawer.

## Trash not compacted:

- Drawer must be at least  $\frac{1}{3}$  full to see compaction.

## Not enough compaction or force:

- Compacting works best when only a few items are loaded. Use the compacting cycle frequently.

## Bottles don't break:

- Not all bottles will break every time, depending upon trash load below them.

## Drawer won't open:

- Drawer will open only when ram is all the way up.
- To raise the ram, push drawer in firmly; turn key-knob to START; release key-knob.
- Open drawer; lay cans and bottles flat in center of drawer.
- Start compactor again.

## If You Need Service

- Call the authorized Jenn-Air Service Contractor listed in the Yellow Pages or the dealer from whom your appliance was purchased.
- Your Jenn-Air Service Contractor can provide better and faster service if you can accurately describe problems and give model and serial number of the appliance. Be sure to retain proof of purchase to verify warranty status. Refer to WARRANTY for further information of owner's responsibilities for warranty service.

**NOTE:** Complete service and parts literature are available from any authorized Jenn-Air Parts Distributor.

All specifications subject to change by manufacturer without notice.